

1170 and 1180 100 Pound Capacity Drawer Slide Mounting Instructions

Easy Installation Instructions Enclosed

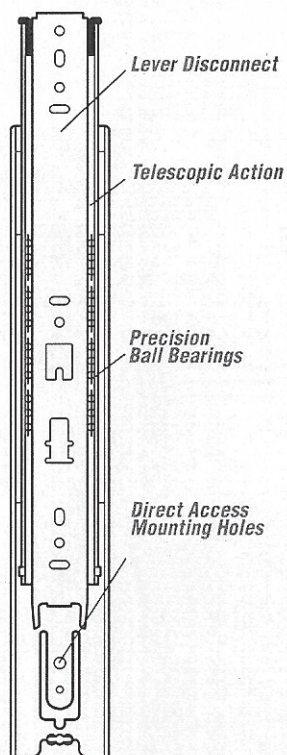

Drawer Slide Mounting Profile

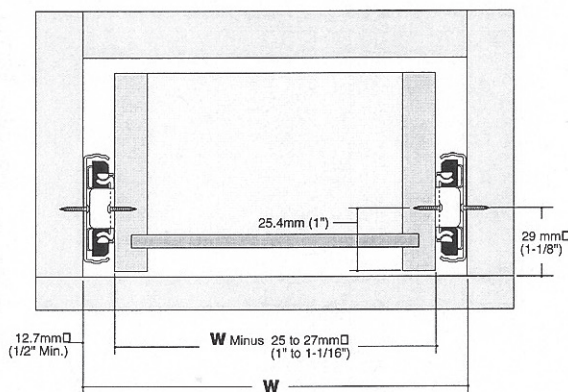

Drawer Release Lever

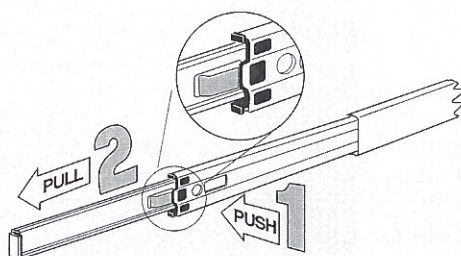

Rear Mounting Bracket

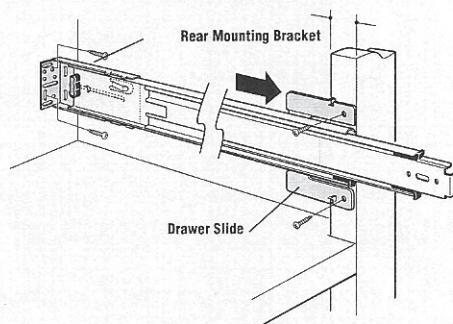

Instructions for the CSH 1170 and 1180 Full Extension Drawer Slides:

Note: When replacing existing drawer slides, confirm that the new slide has a load rating that will meet expected drawer load, uses a similar mounting style, is the correct length and will fit within the available space. Requires a minimum clearance of 1/2" per drawer side. Drawer must be 1" to 1-1/16" less than cabinet opening.

Existing Cabinetry Installation

1. Remove the drawer.
2. Remove the existing drawer slides from the drawer box and cabinet.
3. Prepare the the cabinet and drawer for the new slides by filling old holes and sanding any rough spots that may interfere. Proceed to New Cabinetry Installation.

New Cabinetry Installation

Separate the slide members by depressing the release lever.

1. Install drawer members

Place the front edge of each member 1/16" for face frame cabinets or 1/8" for 32mm frameless cabinets from the rear face of the drawer front. Fasten each drawer member using two pan-head screws per member through the vertical slots only. Check that the ball retainer is moved fully forward to the stop.

2. Install cabinet members

Fasten each cabinet member into place using One screw through the front mounting hole and one through the rear mounting hole as well as one in the optional* 39.1170 rear mounting bracket. For 32mm frameless cabinets, check the hole pattern of the cabinet members with those of the cabinet - the pattern on the cabinet should be set back 1-1/2" from the cabinet face. Place the cabinet member 2mm from Euro hole pattern. Vertically align and install members in the desired position.

3. Insert, adjust and secure

Move the ball retainer to the front of the cabinet member. Insert the drawer by placing the drawer member between the ball bearings and carefully pushing the drawer until it closes. Open and close the drawer to check fit and operation. Make any necessary adjustments and place the remaining screws.

***Optional Rear Bracket Mounting Instructions:** Fasten two 1" x 2" wood mounting strips to the rear inside wall. Align the wider face of the strips parallel to the face frame. Position and fasten rear mounting brackets to the strips. Install two screws into each bracket after adjusting. Place each member flush with the front of the cabinet opening. Make sure it is perpendicular to the cabinet front and in a level position.